

УДК 621.436.068.8:66.067.3

A. N. Kartashevich, V. A. Belousov, A. V. Kravets
Belarusian State Agricultural Academy

TECHNIQUES FOR THE TOXICITY REDUCTION OF EXHAUST GASES FROM THE DIESEL ENGINES ON MOBILE MACHINERY

The technique and results of monitoring research into the pollution with heavy metals of the soils adjacent to M1 highway (Brest—Minsk—boundary line of the Russian Federation) are put forward.

The installation of the plasma-chemical reactor in the exhaust system of the diesel engine applied to the mobile automotive engineering is under study. The type of the plasma-chemical reactor on offer develops the electrodischarge plasma-chemical technology for cleaning exhaust gases. The optimized parameters in the electrode systems of the plasma-chemical reactor allow gaining the best performance characteristics.

Key words: diesel engine, exhaust gas, heavy metals, plasma-chemical reactor, electrode systems.

Introduction. Today the improvement of ecological indices is acute in combustion engine upgrading. Recently much attention has been paid to the methods of exhaust gas (EG) extra cleaning from harmful substances at the stage of gas release, as the reserves of engine improvement are almost exhausted.

For the mobile motor and tractor vehicles the most promising solution to the problem can be the use of the sputter-ion plasma-chemical technology of gas cleaning. This technology intends to set the plasma-chemical reactor (PCR) in the gas exhaust system of the engine. Being the devices of direct energy conversion, plasma-chemical reactors provide the high-level efficiency of EG cleaning both from hard particles (HP) contributing to the lower effective soot level.

The paper also discloses the negative effect of EG toxic components on the environment, and the results of the theoretical and experimental research on the application of the low-temperature non-equilibrium plasma in the EG cleaning systems of diesel engines with useful capacity up to 5 dm³ (cubic decimeters), which are used as power units on the agricultural tractors.

Research technique. For the purpose of the analysis of the negative effect of EG toxic components on the environment the monitoring research has been carried out. The aim of monitoring researches was to determine the index of soil pollution by the EG toxic components on the territories around the busy motorways.

The monitoring research was carried out in the following way [1]: 12 checkpoints were selected long the motorway Brest—Minsk—frontier of the Russian Federation at a distance of 50 + 12 km (picture 1); sampling selection was done with a sampler from a depth of 3...6 cm on both the sides of the motorway at a distance of 1, 10, 100 m and directly near the solid pavement. Thus, we have obtained 96 soil samples and carried out the chemical analysis of the mobile forms of the heavy metals' content.

For the purpose of general pollution evaluation along the whole length of the motorway M1 we marked out the zone with a maximum heavy metals concentration of 0...10 m (lands, which aren't used in agriculture) and a zone within 10...100 m (lands, which are used in agricultural production).

The concentration of heavy metals in soot, extracted from the interior surfaces in gas-discharge systems of different size types of diesel engines, was determined by means of the atomic absorptive spectrophotometer AAS-30.

The research technique in the parameter optimization of the sputter-ion plasma-chemical system was aimed at searching for the constructive variant of electrode possessing the outmost discharge characteristics, the dependence of the integral discharge characteristics of electrode systems on the parameters of gas flow, blasting the corona discharge.

The program of the research in optimizing the electrode system parameters envisaged: constructing the experimental volt-ampere characteristics of the electrode systems; finding out the optimal needle spacing in the

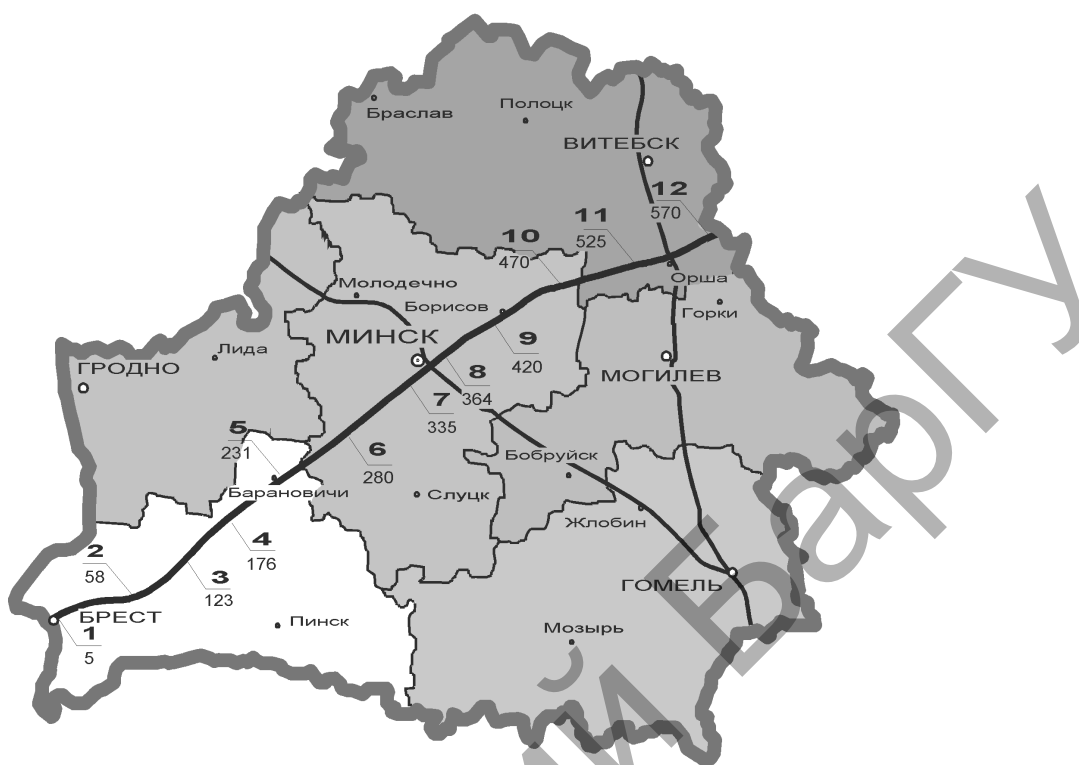

Picture 1. — Location of the checkpoints along the motorway Brest—Minsk—frontier of the Russian Federation

complex point system “line with needles — plane” and “plane with needles — plane”; defining the dependence of the initial potential of the corona discharge of the system “plane with needles” on needles operating altitude; putting forward the particular features of the corona discharge on the needle points in EG flow of diesel engine (integral discharge characteristics dependence on the EG temperature, EG speed and exhaust opacity).

The volt-ampere characteristics of electrode systems were measured on the still air (with the control of free air temperature, moisture and pressure) and in the EG flow at various speeds and under power conditions of diesel engine work. The corona voltage ignition is determined by employing the method of reducing characteristics.

The optimal needle spacing in complex point system “line with needles — plane” and “plane with needles — plane” was determined under the experimental research of model samples of electrode systems with movable discharge needles (picture 2, *a*, and 2, *b*). During the experiment the needles spacing changed from the minimum possible value to the value of interelectrode distance. For each spacing value the integral discharge characteristics of all the range of system working voltages were attested. At the same time the value of interelectrode distance in every experiment was constant.

The EG cleaning efficiency of the developed PCR model was investigated during the stand testing of diesel engine Д-243 (rated power — 65 kW, rated engine speed — 2 200 min⁻¹, rated EG blast intensity — 730 m³ per hour), that were carried out on the electro-braking stand RAPIDO (Germany) with the power of 250 kW. The stand was equipped with the devices and equipment for the control of main indices of engine performance and EG toxicity. The exhaust opacity was determined by the sootmeters «ДО-1» (Belarus), «Смор-1» (Russia), “ENERAC-200” (USA). The testing included the comparisons of diesel ecological indices in two cases of gasexhaust system: the first case — the standard gas exhaust system, the second case — the gas exhaust system with PCR [2].

Research results. The analysis of the results of monitoring research shows that the concentration of mobile forms of heavy metals in the soil near the motorway M1 varies from the level, close to normal, to the level 4.5 times higher than normal [3]. It was determined that the level of pollution increases in the area around the cities Brest, Minsk and Russian Federation frontier due to the traffic intensity increase (picture 3).

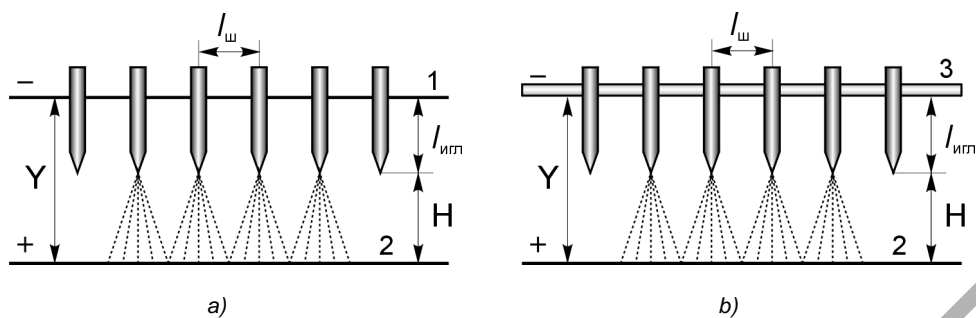

a — “plane with corona needles — plane”; b — “line with the needle — plane”; 1 — potential plane with needles; 2 — grounded plane; 3 — potential line with needles; H — interelectrode distance, m; l_m — operating altitude of corona needles, m; l_w — needle spacing, m; Y — the distance between electrode bases, m

Picture 2. — The scheme of electrode systems

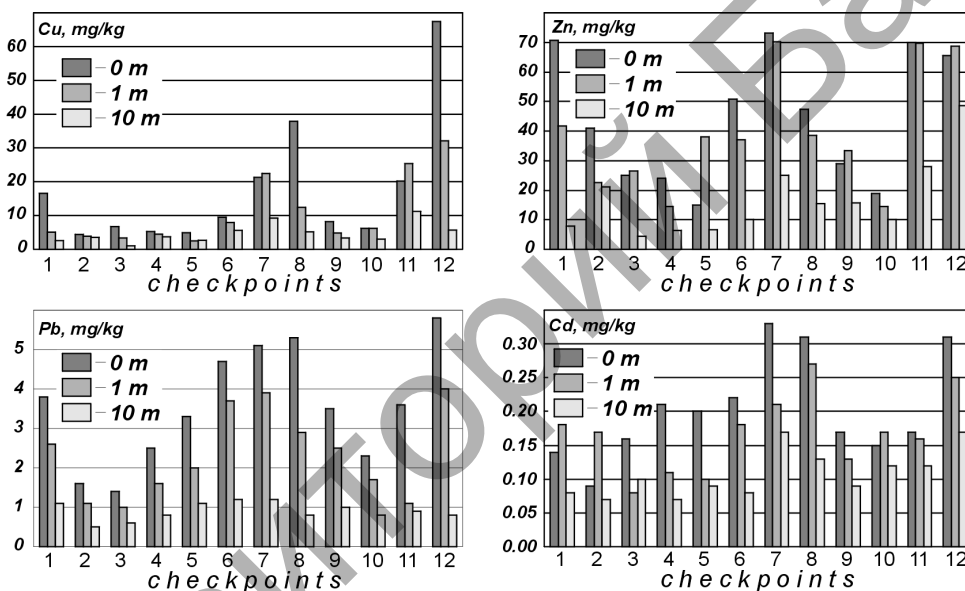

Picture 3. — The level of actual soil pollution with the mobile forms of heavy metals along the motorway M1

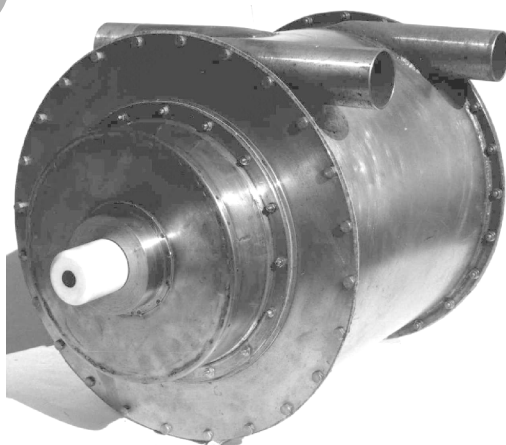

Picture 4. — The experimental model of full-flow plasma-chemical reactor for diesel Д-243

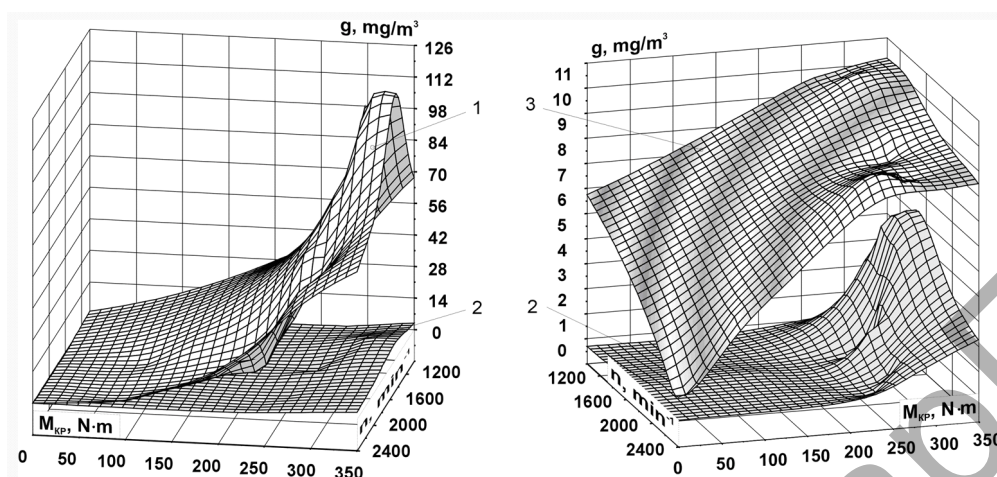

1 — the standard gas-outlet system; 2 — gas outlet system with PCR; 3 — the requirements of EURO-3 standard recalculated in operation conditions of diesel Д-243; g — the concentration of heavy particles in diesel EG, mg/m^3 ; n — the frequency of crankshaft rotation, min^{-1} ; $M_{\text{кр}}$ — the twisting moment of engine, $\text{H} \cdot \text{m}$

Picture 5. — Exhaust opacity of diesel Д-243

The results of the chemical analysis of diesel soot show that the concentration of heavy metals in soot exceeds greatly their concentration in soil and is equal to: Cu — 42 mg / kg, Zn — 802 mg / kg, Pb — 23 mg / kg, Cd — 0.57 mg / kg [4]. This fact together with high level of annual soot pollution (the annual level of soot pollution by diesel truck tractors equals to 1 500 kg / km [5]) shows that soot is one of the main sources of soil pollution with heavy metals.

As a result of optimizing the parameters of sputterion systems we developed the model of multidisk electrode system and worked out the experimental model of plasma-chemical reactor (picture 4).

The process of exhaust opacity reduction in plasma of stationary corona discharge of full-flow plasma-chemical reactor takes place when the level of voltage in the electrode system exceeds a level of 6.5...8.0 kW, that is the voltage level of corona ignition. When the voltage level exceeds a potential of 14...15 kW, plasma-chemical reactor reaches the mode of saturation. Further increase of voltage level is not expedient because it leads to the large increase of specific power consumption with the low additional level of cleaning.

On picture 5 the dependence of diesel exhaust opacity on the frequency of crankshaft rotation and the load for all the speed and loading range is shown (surface 1), diesel exhaust opacity with the system of soot cleaning (surface 2) and also the requirements of EURO-3 standard recalculated in operation conditions of diesel Д-243 (surface 3).

As we see, the PCR provides effective EG cleaning from soot on all the speed and loading range of engine operations. In the sphere of loading conditions, which correspond to zones with maximum level of twisting moment, the maximum level of exhaust opacity after the EG cleaning equals 2.3% or 0.041 g / kWh. That is 2.44 times lower than requirements of EURO-3 standard and 1.94 times lower than requirements of EURO-5 standard.

Conclusion. To provide the level of diesel exhaust opacity satisfying the requirements of modern standards we need additional EG cleaning by means of the devices, which are employable in the gas-discharge system. Based on the analysis and synthesis of main factors, determining the efficiency of the process of exhaust opacity reduction in the process of gas discharge, it's established that one of the main directions is the use of plasma-chemical reactors for the EG cleaning in the medium of low-temperature plasma. It allows to provide a high level of EG cleaning from particles and gaseous toxic components with the low level of energy consumption.

The stand tests of the developed model of full-flow plasma-chemical reactor together with diesel Д-243 show that in rated power conditions in plasma of stationary corona discharge the PCR provides the exhaust opacity reduction to 97%, nitric acid impoverishment to 14 % herewith the energy consumption rate in EG flow

about 0.7 watt-hour / m³. In the plasma of impulse streamer corona under the combined discharge feeding conditions, the PCR provides the exhaust opacity reduction from 96%, nitric acid impoverishment to 24% herewith the energy consumption rate in EG flow about 2.3 watt-hour / m³.

References

1. Kartashevich A. N., Belousov V. A., Sushnyou A. A. The soil pollution with heavy metals along the motorways in the Republic of Belarus // Natural resources. 1998. № 1. P. 114—120.
2. Plazmochemiczna metoda oczyszczania z sadzy spalin silników wysokoprężnych / A. N. Kartaszewicz [et al.] // Przegląd techniki rolniczej i leśnej. Warszawa. 2001. № 2. P. 11—13. ; Sushnyou A. A. Concentration of heavy metals in diesel soot // Youth, science, agricultural education and production : papers collection of sci.-pract. conf. Vitebsk : VSAVM, 1999. P. 206—208. ; Sushnyou A. A. Experimental research of sputter-ion systems for diesel engine exhaust opacity reduction // Actual problems of agricultural mechanization : materials of intern. sci.-pract. conf. Part 2 / BSAA / Gorki, 2001. P. 245—249.
3. Kartashevich A. N., Belousov V. A., Sushnyou A. A. The soil pollution with heavy metals along the motorways in the Republic of Belarus. P. 114—120. ; Development and research of sputter-ion plasma-chemical systems for the reduction of exhaust opacity and exhaust gas toxicity of diesel engines with useful capacity up to 12 m³ / H. M. Vasiliev [et al.] // Ecological aspects of mechanization of plant production 7 Intern. symp. / Warszawa, 2001. P. 284—290.
4. Sushnyou A. A. Concentration of heavy metals in diesel soot. P. 206—208.
5. Belousov V. A., Sushnyou A. A. Exhaust opacity of lorries passing through the territory of the Republic of Belarus // Technical higher educational establishments — for the Republic : materials of 52nd Intern. sci.-tech. conf. : in 7 parts. Minsk, 1997. Part 3. P. 65.

В работе приводятся сведения о негативном воздействии токсичных компонентов отработавших газов на окружающую среду, а также результаты теоретических и экспериментальных исследований по применению низкотемпературной неравновесной плазмы в системах очистки отработавших газов дизельных двигателей рабочим объемом до 5 дм³, использующихся в качестве силового агрегата на мобильной технике.

Проведенные мониторинговые исследования негативного воздействия токсичных компонентов отработавших газов на окружающую среду предполагали определение величины загрязнения почв, прилегающих к крупным автомагистралям, токсичными компонентами отработавших газов дизельных двигателей.

Для мобильной автотракторной техники наиболее перспективной с точки зрения очистки отработавших газов может стать электроразрядная плазмохимическая технология газоочистки, предполагающая установку в системе выпуска дизельного двигателя плазмохимического реактора.

Ключевые слова: дизельный двигатель, отработавшие газы, тяжёлые металлы, плазмохимический реактор, электродная система.